

Legacy Model	ARI tons water	40% PG	Flow rate Nom water (GPM)	Flow rate 40 % PG (GPM)	Flow rate Min (GPM)	Flow rate Max (GPM)	Cooler Selection	Cooler Feeds	Target flow Rate GPM	Target Leaving Temp (F)
12S	1.2	1.2	2.88	2.88	8	15	DFT005	8 feeds	8.00	45.70
18S	1.7	1.6	4.08	3.84	8	15	DFT005	8 feeds	8.00	45.70
24S	1.9	1.8	4.56	4.32	8	15	DFT005	8 feeds	8.00	45.70
30S	3	2.8	7.2	6.72	8	15	DFT005	8 feeds	8.00	45.70
36S	3.4	3.2	8.16	7.68	8	15	DFT005	8 feeds	8.00	45.70
48S	4.2	4	10.08	9.6	8	15	DFT005	8 feeds	9.60	44.60
50S	4.7	4.5	11.28	10.8	8	15	DFT005	8 feeds	10.80	45.40
60S	5.2	5	12.48	12	8	20	DFT008	12 feeds	12.00	41.60
70S	6.6	6.2	15.84	14.88	8	20	DFT008	12 feeds	14.88	43.60
80S	7.6	7.2	18.24	17.28	15	30	DFT010	16 Feeds	17.28	42.90
90S	8.8	8.4	21.12	20.16	15	30	DFT010	16 Feeds	20.16	44.40
120S	10.2	9.6	24.48	23.04	15	30	DFT010	16 Feeds	23.04	46.30
180S	12.9	12.2	30.96	29.28	15	30	DFT010	16 Feeds	29.28	49.90
250S	18.4	17.4	44.16	41.76	40	110	DFT021	48 Feeds	41.76	45.40
300S	22.2	21	53.28	50.4	40	110	DFT021	48 Feeds	50.40	48.50
72D	6.8	6.4	16.32	15.36	15	30	DFT010	16 Feeds	15.36	41.70
96D	8.4	7.9	20.16	18.96	15	30	DFT010	16 Feeds	18.96	43.80
100D	9.3	8.8	22.32	21.12	15	30	DFT010	16 Feeds	21.12	45.00
120D	10.4	9.8	24.96	23.52	15	30	DFT010	16 Feeds	23.52	46.40
140D	13.1	12.4	31.44	29.76	15	30	DFT010	16 Feeds	29.76	50.20
160D	15.2	14.3	36.48	34.32	20	60	DFT010	24 Feeds	34.32	51.80
180D	17.6	16.6	42.24	39.84	40	110	DFT021	48 Feeds	40.00	44.80
180M	12.7	12	30.48	28.8	40	110	DFT021	48 Feeds	40.00	44.80
240D	20.1	19	48.24	45.6	40	110	DFT021	48 Feeds	45.60	46.80
360D	25.8	24.4	61.92	58.56	40	110	DFT021	48 Feeds	58.56	50.90
500D	36.5	34.5	87.6	82.8	40	110	DFT021	48 Feeds	82.80	45.90
600D	44.3	41.9	106.32	100.56	40	110	DFT021	48 Feeds	100.56	48.40
701D	59.2	55.9	142.1	134.2	60	180	BFH060	42 Feeds	134.20	49.00
800D	64.2	60.7	154.1	145.7	60	180	BFH060	42 Feeds	145.70	50.40
1000D	80.8	76.4	193.9	183.4	120	350	BFH090	84 Feeds	183.40	48.50
1200D	91.3	86.3	219.1	207.1	120	350	BFH090	84 Feeds	207.10	50.30

Conditions; Chiller at ARI with 40 % PG

Fluid Cooler based at 35°F Flow @2.5 GPM/ton

Overview

Our engineers have carefully selected and matched components to provide excellent performance, long service life and a wide range of performance selections. Specifically engineered for outdoor installations, the DFT and BFH fluid coolers are constructed of aluminum and heavy gauge galvanized steel to resist corrosion in all climates.

Fluid coolers are available in a wide range of sizes. Each model is available with several circuit options to ensure the exact fluid cooler for your requirements. Our fluid coolers are designed to reduce the cost of time required for installation. Each unit is completely assembled and tested at the factory. All motor leads are wired to a junction box providing a single point for field wiring.

Direct-Drive Design Features

- Cabinets are heavy-duty construction and designed for outdoor applications; tube sheets and all structural members are fabricated from galvanized steel
- Cabinet panels are fabricated from heavy-gauge aluminum for an attractive appearance and corrosion protection
- Coils are fabricated with corrugated aluminum fins with staggered copper tubes for optimum heat transfer; all units are pressure-tested, dehydrated and pressurized prior to shipment
- Alternate coil constructions are available — copper fins, BohnGuard™ fins and coated coils
- BFH models incorporate the Floating Tube™ coil design that reduces the possibility of tube sheet leaks
- DFT models available in either horizontal or vertical air flow; BFH models available in vertical air flow only
- Fully baffled fan sections provide structural strength and prevent fan wind-milling in the off cycle
- Energy efficient fan motors with direct-drive fans available at 1140 RPM; fan motors have thermal overload protection and permanently lubricated ball bearings
- DFT models are available in 208-230 V single-phase, 208-230/460 dual-voltage, three-phase or 575 V three-phase motors; BFH models are available in 208-230/460 dual voltage, three-phase or 575 V three-phase motors
- Statically and dynamically balanced fan blades are aluminum and riveted to painted steel spider and hubs
- Fan guards are PVC coated steel for optimum corrosion protection
- All fan motor leads are wired to a weatherproof electrical enclosure for single-point field wiring
- Fan cycling controls are available that cycle all fans in response to BFH only; DFT fan cycling is ambient air
- All controls are factory mounted and wired; control circuit voltage is 230 V standard, 24 and 115 V controls are also available
- A wide selection of circuit options maximizes performance at minimal cost
- Sizes available from 10 GPM through 500 GPM
- Units are UL listed for US and Canada

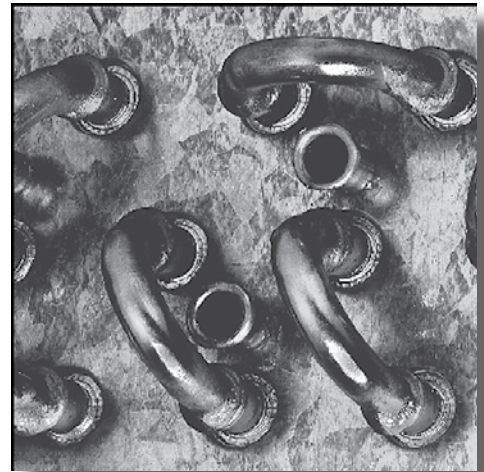

*The Floating Tube™ Coil Design
Dramatically Reduces Tube Sheet Leaks*

Specifications and Dimensions

Diagram 1. Model DFT Dimensions, 5 through 26 Tons with Vertical Air Flow

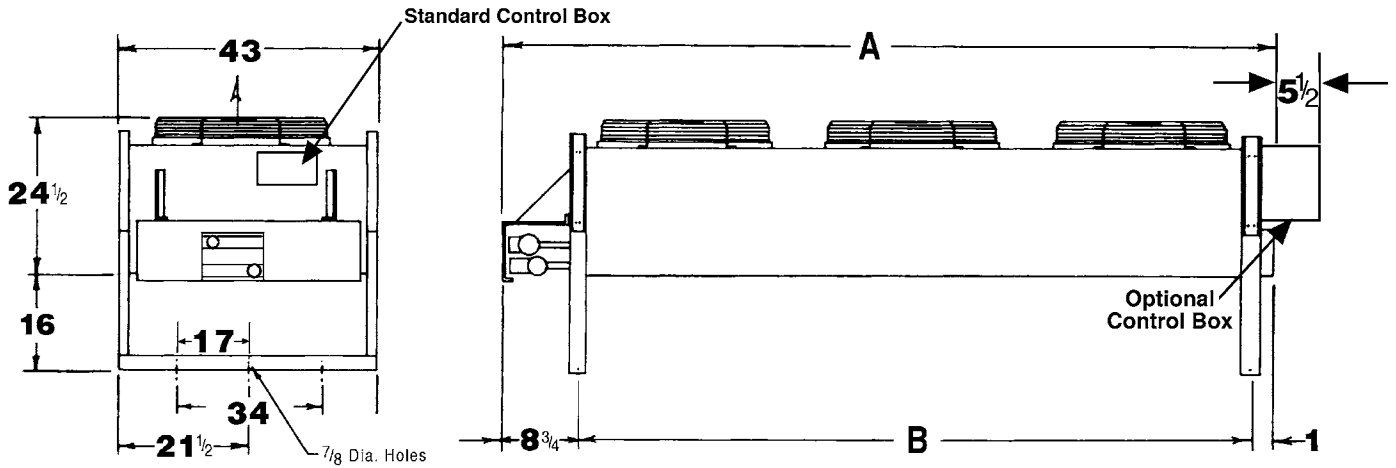

Diagram 2. Model DFT Dimensions, 5 through 26 Tons with Horizontal Air Flow

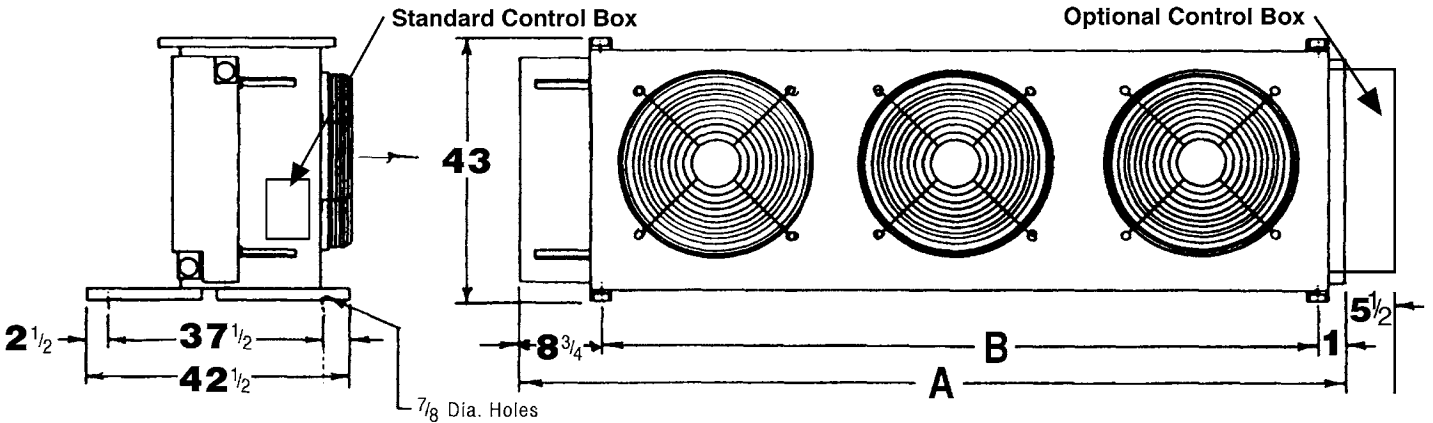

Table 8. Model DFT Specifications

Model	Dimensions (in.)		CFM	Fan		Motor Data				Approx. Net Wt. (Lbs.)
	A	B		No.	Dia.	HP ¹	FLA ¹	HP ²	FLA ²	
DFT005	39-3/4	30	5,050	1	24	1/3	3.4	1/3	2.6/1.3	205
DFT008	49-3/4	40	6,450	1	26	1/2	3.9	1/3	2.6/1.3	260
DFT010	69-3/4	60	10,100	2	24	1/3	6.8	1/3	5.2/2.6	330
DFT012	69-3/4	60	12,400	2	26	1/2	7.8	1/3	5.2/2.6	348
DFT014	89-3/4	80	13,700	2	26	1/2	7.8	1/3	5.2/2.6	420
DFT016	89-3/4	80	12,900	2	26	1/2	7.8	1/3	5.2/2.6	436
DFT021	129-3/4	120	20,500	3	26	1/2	11.7	1/3	7.8/3.9	565
DFT023	129-3/4	120	19,900	3	26	1/2	11.7	1/3	7.8/3.9	580
DFT026	129-3/4	120	19,400	3	26	1/2	11.7	1/3	7.8/3.9	610

¹ Motor voltage 208-230/1/60; 1075 RPM

² Motor voltage 208-230-460/3/60; 1140 RPM

Dimensions

Diagram 3. Model BFH Dimensions

End Views

Side Views

Single Row

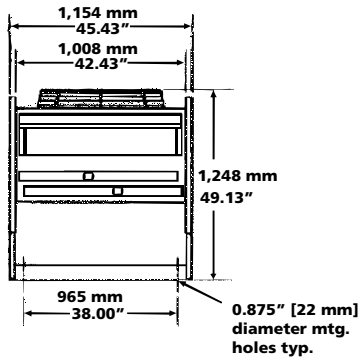

Double Row

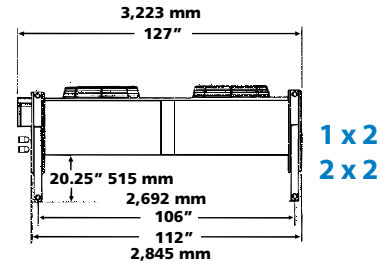
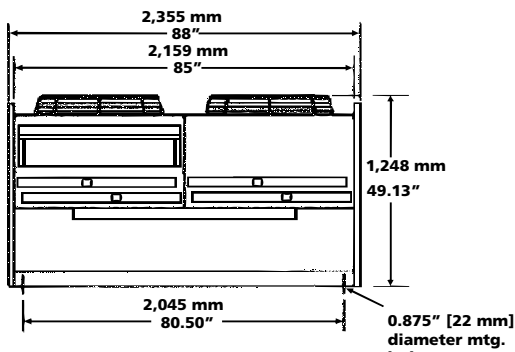

1 x 2
2 x 2

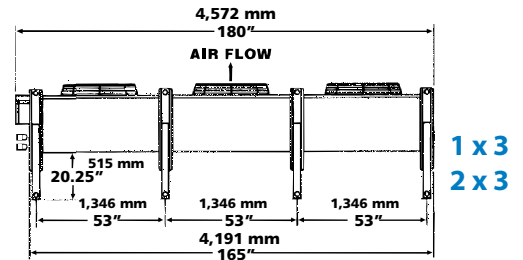

1 x 3
2 x 3

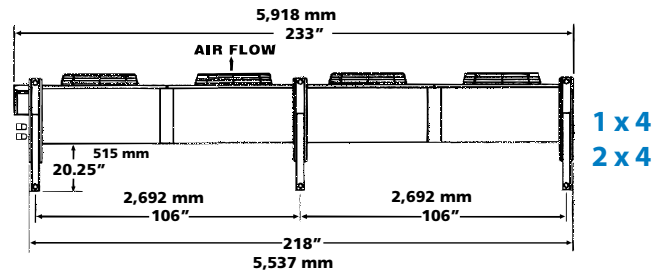

1 x 4
2 x 4

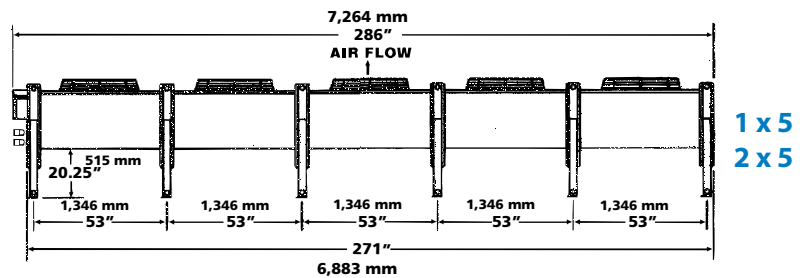

1 x 5
2 x 5

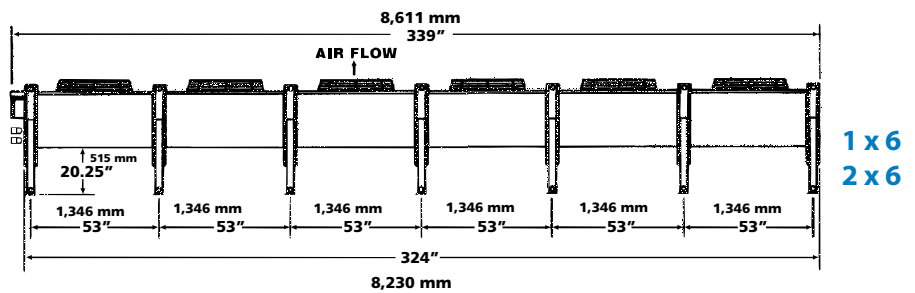

1 x 6
2 x 6

Model BFH