

PRODUCT DATA SHEET

Model: **RRT200**

*200 Gallon Dual Process
Tank & Pump Package*



Legacy Chiller Systems

851 Tech Drive
Telford, PA 18969

Toll-Free: (877) 988-5464

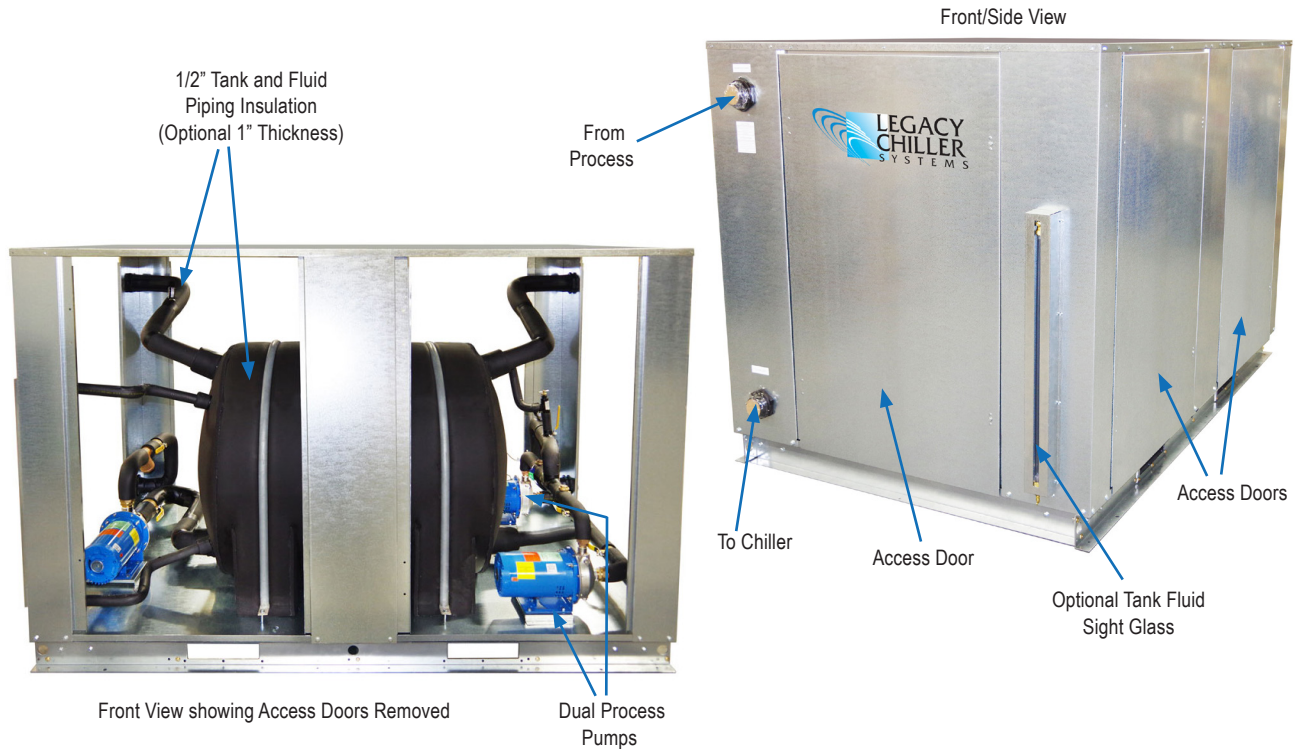

(Polyethylene Tank) **Standard Features:**

- Open Vented **200 gallon Polyethylene tank**
- 1/2" tank and fluid piping insulation
- SCH80 PVC and Polypropylene piping
- Fused, **STAINLESS STEEL** evaporator recirculating pump
- Recirculation pump discharge ball valve and cleanable "Y" strainer
- Control box with pump terminal block
- Galvanized steel sheet metal cabinet
- Hinged removable access panels

Available Options:

- **STAINLESS STEEL SEALED TANK**
- Fused, **STAINLESS STEEL** process pump
- Dual process pump with manual changeover
- Dual process pump with auto changeover
- Pump suction isolation valve
- **Process Pump VFD Controller**
- **Tank fluid sight glass**
- Tank liquid level indicator with dry contacts
- Low flow by-pass valve
- **Water flow meter**
- Auto city water make up solenoid
- 1" tank and piping insulation in lieu of 1/2"
- Seal-tight electrical conduit and connections
- **Painted - Powder Coated**



PRODUCT DATA SHEET

Model: RRT200
*200 Gallon Dual Process
 Tank & Pump Package*



Legacy Chiller Systems
 851 Tech Drive
 Telford, PA 18969
Toll-Free: (877) 988-5464

Polyethylene Tank & Pump

Tank Model	Length Inches	Width Inches	Height Inches	Water Conn.	Tank Capacity	Recirculation Pump	FLA 230/30	FLA 460/3Ø	Weight Lbs.
RRT200	88	56	60	2" FPT	200 Gallons	3HP	9.4	4.5	445

Product Dimensional Drawing

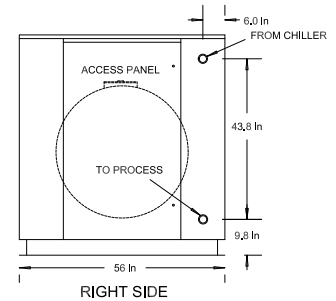
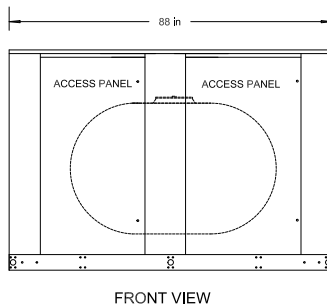
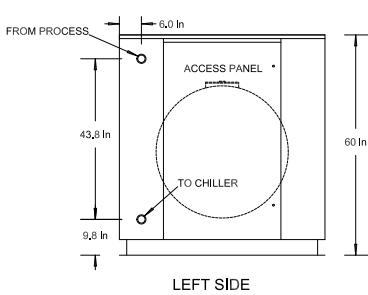
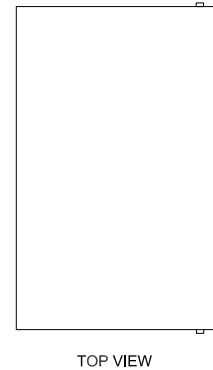
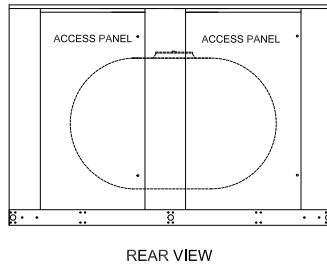
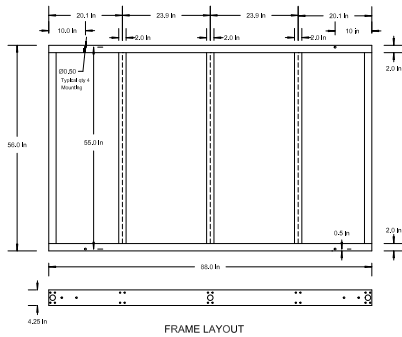

- NOTES:
- 1) CONNECTION SIZE
 200 GAL - 2" FPT
 300 GAL - 2.5" FPT
 - 2) WEIGHT
 DRY - 975 Lbs.
 OPERATING - 3225 Lbs.