

PRODUCT DATA SHEET

Model: **PZW11D**

*Packaged Water-Cooled
11 Ton Chiller*



Legacy Chillers, Inc.
851 Tech Drive
Telford, PA 18969

Toll-Free: (877) 988-5464

STANDARD ON ALL LEGACY CHILLER MODELS:
Pentra Microsmart, Programmable Logic Controller (PLC)
with HMI Touch Screen Display.

**R454A
Refrigerant**



Electrical Cabinet

User-Friendly
Touch Screen
Display

Process
Fluid Inlet

Process
Fluid
Outlet



Front/Side View

Standard Features:

- Conforms to UL 60335-2-40:2022 Ed.4
UL 60335-1:2016 Ed.6
- CSA C22.2 # 60335-1:2016 Ed.6
- CSA C22.2 # 60335-2-40:2022 Ed.4
- Single Point Power Connection
- Pentra Microsmart, Programmable Logic Controller (PLC) with easy to use HMI touch screen display
- **STAINLESS STEEL**, brazed plate evaporator
- Scroll compressor with crankcase heater
- Suction Accumulator
- Liquid line drier, sight glass, solenoid
- Electronic expansion valve
- Manual high pressure cutout
- **Water flow switch**
- **Hot Gas Bypass Capacity Control**
- **24V control transformer**
- Control circuit fusing
- Condenser(s): Coaxial up to PZW18D
- Condenser(s): Shell and Tube on units larger than 18 ton
- Compressor motor contactor
- **Painted - Powder Coated** (up to PZW18D), **galvanized sheet metal cabinet**
- 1/2" insulation on all water and refrigerant lines
- Complete refrigerant charge from factory
- **Factory Performance Test prior to shipment**



Options:

- **VFD Compressor Control**
- **Copeland Digital Scroll Compressor**
- **Remote Idec touchscreen control panel**
- **5 Port Ethernet Switch**
- **BacNet Gateway**
- **Process Pump VFD Controller**
- 4 year extended compressor warranty
- Casters (factory mounted)
- Condenser water regulating valve
- 115 volt (rain tight) service outlet
- Non Fused Disconnect
- Phase Monitor, line voltage monitor offering protection against phase loss/reversal, unbalance and hi/lo voltage
- Compressor fusing
- Compressor Sound Cover
- Factory installed evaporator heat tape freeze protection
- Low flow by-pass valve
- Fused, **STAINLESS STEEL** process pump
- Pump suction isolation valve
- Water pressure gauge set
- Water Flow Meter
- Auto city water changeover panel with filter
- Stainless steel, SCH80 PVC or Polypropylene piping for deionized and reverse osmosis water systems
- Door Mounted HMI with weather proof cover

PRODUCT DATA SHEET

Model: PZW11D
Packaged Water-Cooled
11 Ton Chiller



Legacy Chillers, Inc.
 851 Tech Drive
 Telford, PA 18969
 Toll-Free: (877) 988-5464

Dimensional & Electrical Table (Dual Circuit)

Chiller Model	Nominal BTUH	Length Inches	Width Inches	Height Inches	Power			Compressor Qty.	RLA ea.	LRA ea.	MCA	MOP	Chiller Fluid Conn	Weight Pounds
					Voltage	Phase	Freq.							
PZW11DE7	138200	65	34	36	208/230	1	60	2	28.2	129	63	90	1.25 "FPT	775

Capacity Table (Refrigerant R454A)

Model	COMPRESSOR	COND(°F)	105		
		LWT (°F)	TONS	KW	EER
11D	YB38KAE	42	10.8	10.6	12.3
		44	11.3	10.6	12.8
		45	11.5	10.6	13.0
		50	12.7	10.7	14.3

- Capacities on this chart are based on refrigerant R454A. Lower leaving water or low ambient can require the use of a glycol solution or other fluid blends. These solutions affect unit capacities. Please consult the factory on these or other special fluids.
- KW input is for compressor(s) only.
- EER = Energy Efficiency Ratio (BTU/watt-hour). Power inputs include compressor (s), condenser fan motor (s) and control power.



Product Dimensional Drawing

R454A
Refrigerant

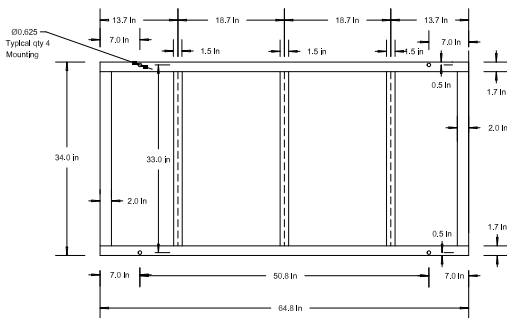

FRAME LAYOUT

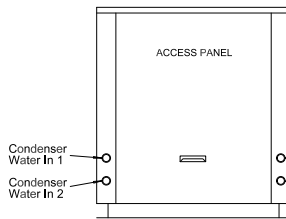

BACK VIEW

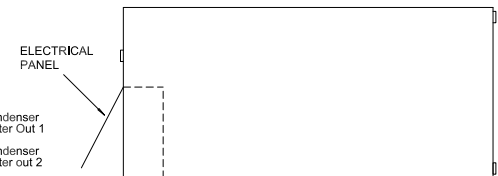

TOP VIEW

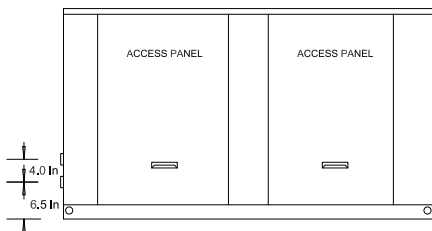

LEFT SIDE VIEW

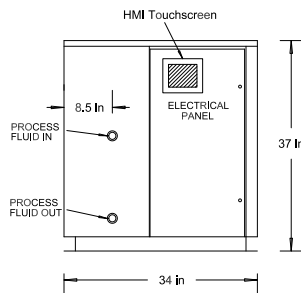

FRONT VIEW

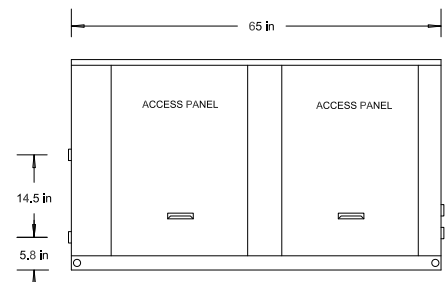

RIGHT SIDE VIEW