

# PRODUCT DATA SHEET

Model: **PZWPT2S**

*Packaged Water-Cooled  
Portable 2 Ton Chiller*



**Legacy Chiller Systems**

851 Tech Drive  
Telford, PA 18969

**Toll-Free: (877) 988-5464**

**STANDARD ON ALL LEGACY CHILLER MODELS:**  
Pentra Microsmart, Programmable Logic Controller (PLC)  
with HMI Touch Screen Display.

User-Friendly  
Touch Screen  
Display



Front View

Factory Mounted  
Casters for  
Portability



Front View showing  
Electrical Cabinet Open

IDEC  
Microprocessor  
Controller

Back View

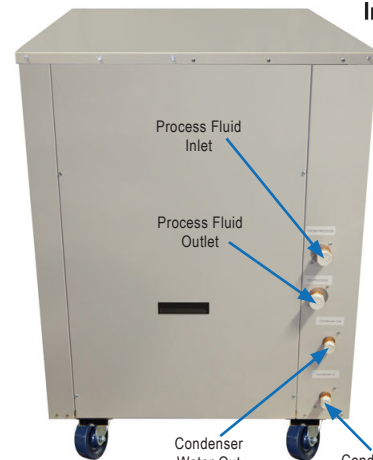

Process Fluid  
Inlet

Process Fluid  
Outlet

Condenser  
Water Out

Condenser  
Water In



## Standard Features:

- ETL listed to UL1995 & CAN/CSA C22.2 No. 236-11, 4th edition, 10/14/2011
- Single Point Power Connection
- Pentra Microsmart, Programmable Logic Controller (PLC) with easy to use HMI touch screen display
- STAINLESS STEEL, brazed plate evaporator
- Scroll compressor with crankcase heater
- Suction accumulator
- Noncorrosive polyethylene storage tank with 1/2" insulation
- Fused, STAINLESS STEEL Process pump with discharge ball valve
- Low flow by-pass valve
- **Water flow switch**
- **Hot Gas Bypass Capacity Control**
- **24V control transformer**
- Rust resistant, high CFM, aluminum condenser fan blade
- Condenser (Water cooled): Coaxial Steel tube / Copper tube
- Compressor motor and process pump contactors
- Process pump and control circuit fusing
- Casters (factory mounted)
- **Painted (Powder Coated), galvanized sheet metal cabinet**
- 1/2" insulation on all water and Low pressure refrigerant lines
- Liquid line drier, sight glass, solenoid, TXV
- Complete refrigerant charge from factory
- **Factory Performance Test prior to shipment**
- **Extended warranty:** See your quote or latest IOM booklet revision

**Easy to Use  
Touch Screen Display  
on all Legacy Chiller  
Models**



## Options:

- Remote Idec touchscreen control panel
- Industrial VPN Router
- 5 Port Ethernet Switch
- BacNet Gateway
- Process Pump VFD Controller
- VFD Compressor Controller
- 4 year extended compressor warranty
- 115 volt (rain tight) service outlet
- Fused Disconnect
- Non Fused Disconnect
- Phase monitor, line voltage monitor offering protection against phase loss/reversal, unbalance and hi/lo voltage
- Compressor fusing
- Compressor sound cover
- Factory installed evaporator heat tape freeze protection
- Process pump suction isolation valve
- Water pressure gauge set
- Stainless steel, SCH80 PVC or Polypropylene piping for de-ionized and reverse osmosis water systems
- Storage Tank Sight Glass
- Tank low fluid level indicator
- Tank auto city water make up solenoid & auto level switch
- Condenser water regulating valve (Water Cooled Models)
- Coastal powder coat paint protection
- **Custom powder coat paint color scheme** (Company Colors & more)
- Weather Proof HMI Cover

# PRODUCT DATA SHEET

**Model: PZWPT2S**  
*Packaged Water-Cooled  
 Portable 2 Ton Chiller*



**Legacy Chiller Systems**  
 851 Tech Drive  
 Telford, PA 18969  
**Toll-Free: (877) 988-5464**

## Dimensional & Electrical Table (Single Circuit)

Chiller Models	Length Inches	Width Inches	Height Inches	Power			Compressor		RLA ea.	LRA ea.	Process Pump FLA	MCA	M.O.P	Process Pump HP	Reservoir Gal.	Chiller Fluid Conn.	Condenser Water Conn.	Weight Pounds
				Voltage	Phase	Freq.	Qty.	HP										
PZWPT2SE5	36	34	41	208/230V	1	60Hz	1	2.5	14.1	75	6.6	25	35	1	12	1" FPT	3/4" FPT	360
PZWPT2SF5				208/230V	3	60Hz			9.9	73	6.6	20	20					
PZWPT2SH5				460V	3	60Hz			5.1	38	1.7	15	15					
PZWPT2SI5				575V	3	60Hz			3.8	28	0.72	15	15					

## Capacity Table (Refrigerant R407C)

Model	Compressor	LWT °F	105°F Condensing		
			TONS	KW	EER
2S	ZS19KAE	42.0	2.16	1.9	12.4
		44.0	2.25	1.9	12.9
		45.0	2.30	1.9	13.2
		50.0	2.53	1.9	14.8



## Product Dimensional Drawing

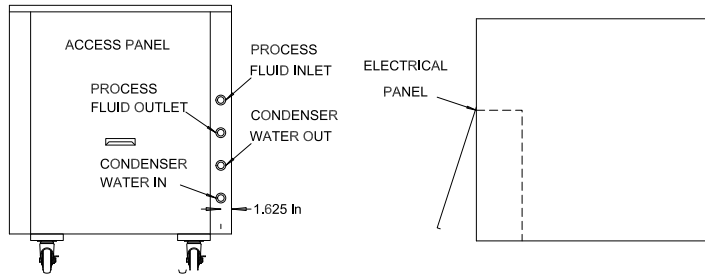

BACK VIEW

TOP VIEW

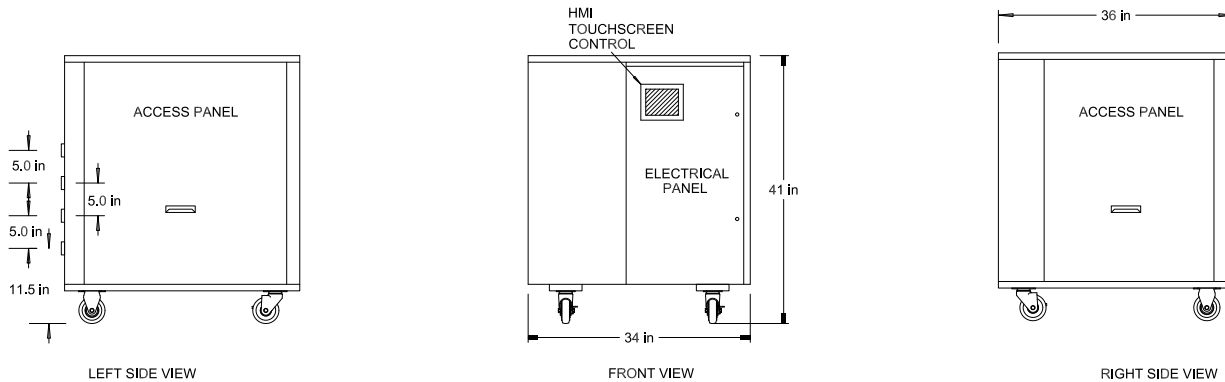

LEFT SIDE VIEW

FRONT VIEW

RIGHT SIDE VIEW