



SCROLL - AIR COOLED PACKAGED & SPLIT SYSTEM CHILLERS



1 to 40 Nominal Tons



Legacy Chiller Systems, Inc. • PH (877) 988-5464 • FX (240) 214-8303

Air Cooled Selection Procedures

To properly select a air cooled packaged chiller, the following information must be known.

1. The required cooling capacity, BTUH.
2. Entering process fluid temperatures.
3. Leaving process fluid temperature.
4. GPM of process fluid to be circulated.
5. Design ambient air temperature.

If you know any three of the items 1 through 4 above you can calculate the fourth by using the formulas below.

For 100% water:

$$\text{Cooling capacity (in BTUH)} = \text{GPM} \times \text{Delta T} \times 500$$

$$\text{GPM} = \frac{\text{Capacity (in BTUH)}}{\text{Delta T} \times 500}$$

$$\text{Delta T} = \frac{\text{Capacity (in BTUH)}}{\text{GPM} \times 500}$$

Sample selection :

Select a air cooled packaged chiller to cool 6.5 GPM of 100% water from 54°F to 44°F.
Design ambient air temperature 95°F.

Find :

A) Air cooled chiller model

Solution :

- A) 1. Chilled fluid Delta T = 54°F - 44°F = 10°F
2. Capacity (in BTUH) = 6.5 GPM x 10°F Delta T x 500 = 32,500 BTUH
3. From the PAC chiller capacity tables, it can be determined that the PAC30S has the capacity to meet the requirements.

***** Consult factory on sizing chillers with glycol or any fluid other than water *****



NOMENCLATURE

Example: **P AC I B 30 S 2 - T3 - Z**

P P = Packaged ES = Evaporator Section CS = Condenser Section

AC AC = Air Cooled Condenser WC = Water Cooled Condenser

I T = Tank Model

B B = Brewery Model L = Low Temp. Model Blank = Standard Unit

30 Nominal Capacity MBTUH Ex. 12 = 12,000 BTUH Etc.

S S = Single Circuit Unit D = Dual Circuit Unit M = Three Circuit Unit

2 1 = R134a 2 = R22 3 = R407C 6 = R404A, R507

T3 Electrical Requirement S2 = 208/230-1-60 S6 = 220-1-50
T3 = 208/230-3-60, T7 = 200/208-3-50
S4 = 460-1-60 T9 = 380-3-50
T4 = 460-3-60
T5 = 575-3-60

Z Compressor Type H = Hermetic, S = Semi-Hermetic, Z = Scroll

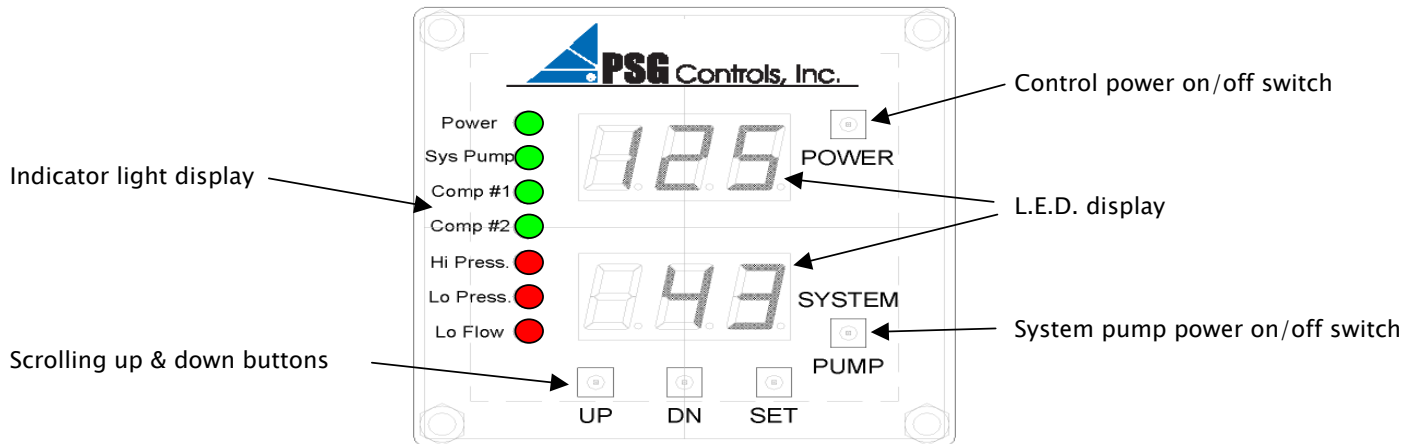

Features:

- Control operates to a $\pm 1^\circ\text{F}$ accuracy.
- Powered from the chiller 24volt control circuit. No high voltage interference.
- 1 or 2 compressor control capability
- Operates and displays in $^\circ\text{F}$ or $^\circ\text{C}$
- Controls chiller on inlet or outlet temperature
- Scroll through set up and review mode
- 30 second compressor time delay to prevent short cycling and nuisance faults
- 60 second hot gas solenoid delay to prevent false hot gas feeding during compressor start up.
- Lock out relay shuts down the chiller when control fault settings activate
- Automatic compressor lead lag on dual circuit chillers
- Weather resistant for outdoor use.
- Basic chiller functionality for ease of set up and operation.
- Factory default function code to reset the controller to the initial factory settings

- Two L.E.D. display windows.
 - a) Inlet & outlet temperature during chiller operation
 - b) Displays refrigerant high and low pressure in review mode
 - 1) no cap tubes to break causing a loss of refrigerant and down time
 - 2) No refrigerant recovery to change out the pressure transducer

- Indicator lights
 - a) Chiller control power on/off switch with green indicator.
 - b) System pump on/off switch with green indicator.
 - c) Compressor run indicator lights
 - d) High and low refrigerant pressure red fault indicator
 - e) Low fluid flow red indicator

- Display flashes all chiller faults.
 - a) Safety faults:

High fluid temperature outlet alarm	- (display only – does not shut down the chiller)
Low fluid temperature outlet alarm	- (shuts down the chiller and requires manual reset)
High refrigerant pressure	- (shuts down the chiller and requires manual reset)
Low refrigerant pressure	- (shuts down the chiller and requires manual reset)
Low water flow through evaporator	- (shuts down the chiller and automatically resets when flow is restored)

- Monitors and logs compressor run hours

PAC & PACT CHILLER STANDARD FEATURES AND OPTIONS

Standard Features (All Models)

- ETL listed 
- *Microprocessor controller*
- *STAINLESS STEEL* brazed plate evaporator with 1/2" insulation, and secured in a steel bracket
- *Shell & tube 180S to 600D models*
- *Scroll* compressor with crankcase heater
- *Suction accumulator*
- *Water flow switch*
- *Hot gas by-pass capacity control*
- *24V control transformer*
- Direct drive condenser fan motor
- Rust resistant, high CFM, aluminum condenser fan blade
- Condenser(s): copper tube / aluminum fin
- Compressor motor contactor
- Condenser motor and control circuit fusing
- "Hard start kit" (single phase units only)
- Painted galvanized sheet metal cabinet
- 1/2" insulation on all water and refrigerant lines
- Liquid line drier, sightglass, solenoid, TEV
- Full refrigerant charge from factory



PAC90S model shown

Additional Features On Tank Models Only

- *STAINLESS STEEL* storage tank with 1/2" insulation
- Fused *STAINLESS STEEL* re-circulation pump for tank operation with ball valve and cleanable strainer
- Tank pressure relief valve, vent and drain connections



PACT60S model shown

AVAILABLE OPTIONS (All Models)

- | | |
|---|---|
| <ul style="list-style-type: none"> • 4 year extended compressor warranty • Casters (factory mounted) • 115 volt (rain tight) service outlet • Fused disconnect • Phase monitor • <i>Compressor fusing</i> • Fan cycle control on Pac90 & 120 units only (+40°F) • Variable fan speed control (+20°F) • Flooded condenser with receiver / head pressure control (-20°F) • Heated flooded condenser with receiver / head pressure control (-20°F) • Factory installed evaporator heat tape freeze protection thermostatically controlled | <ul style="list-style-type: none"> • Fused <i>STAINLESS STEEL</i> system process pump • Dual system pump with manual changeover • Dual system pump with auto changeover • Low flow bypass valve • "Gold" finned condenser coil (coastal protection) • Semi-hermetic compressor • Shell and tube chiller barrel • Water flow meter • Auto city water make up solenoid • Auto city water changeover panel • Auto city water changeover panel with 5 micron filter • Special piping for de-ionized and reverse osmosis water systems • Blower type condenser fan (forward curve) 12S to 60S |
|---|---|

Additional Available Options on Tank Models Only

- | | |
|--|---|
| <ul style="list-style-type: none"> • Storage tank sight glass | <ul style="list-style-type: none"> • Tank low liquid level indicator with dry contacts |
|--|---|

PAC DIMENSIONAL & ELECTRICAL SPECIFICATIONS

Single circuit packaged air cooled chiller

Legacy Model	BTUH @ 95°F amb. 45°F Lwt	Length Inches	Width Inches	Height Inches	Fluid Conn.	Compressor		RLA ea.	LRA ea.	Fan Motor		MCA	M.O.P.	Weight Pounds																										
						Qty.	HP			Qty.	FLA ea.																													
12S2-S2-Z	14,400	36	34	40	3/4" FPT	1	1.3	10	42	1	3.3	20	25	250																										
18S2-S2-Z	21,600														13.6	61.0	3.3	25	30																					
18S2-T3-Z															2.0	8.6	55.0	3.3	15	20																				
18S2-T4-Z															4.3	27.0	1.6	15	15																					
24S2-S2-Z	25,200														56	34	40	1"	1	2.5	15.7	73.0	2	3.3	25	35	275													
24S2-T3-Z																												8.2	63.0	3.3	15	20								
24S2-T4-Z		4.3	31.0	1.6	15	15																																		
30S2-S2-Z	36,000	85	34	40	1.25"	1	3.5	20.7	127.0	2	3.3	30	45	300																										
30S2-T3-Z																												13.9	88.0	3.3	25	30								
30S2-T4-Z																												7.1	44.0	1.6	15	15								
36S2-S2-Z	42,000														85	34	40	1.25"	1	4	25.0	132.0	2	3.3	35	50	500													
36S2-T3-Z																												15.0	115.0	3.3	25	35								
36S2-T4-Z																												7.4	47.5	1.6	15	15								
48S2-S2-Z	50,400	85	34	40	1.25"	1	5	30.1	175.0	2	3.3	45	70	550																										
48S2-T3-Z																												20.7	115.0	3.3	30	45								
48S2-T4-Z																												8.9	63.0	1.6	15	20								
50S2-S2-Z	56,400														85	34	40	1.25"	1	5	27.9	129.0	2	3.3	40	60	575													
60S2-T3-Z	20.7																											156.0	3.3	30	45									
60S2-T4-Z	11.5																											70.0	1.6	20	25									
70S2-T3-Z	81,600	85	34	40	1.25"	1	8	32.1	195.0	2	3.3	50	80	700																										
70S2-T4-Z	16.4																											95.0	1.6	25	40									
80S2-T3-Z	93,600																											85	34	40	1.25"	1	9	33.6	225.0	2	3.3	50	80	725
80S2-T4-Z	17.3														114.0	1.6	25	40																						
90S2-T3-Z	106,800														85	34	40	1.25"	1	10	42.0	239.0	2	3.3	60	100	750													
90S2-T4-Z	19.2																																							
120S2-T3-Z	123,600	85	34	40	1.25"	1	12	47.0	245.0	2	3.3	70	110	850																										
120S2-T4-Z	22.1																																							

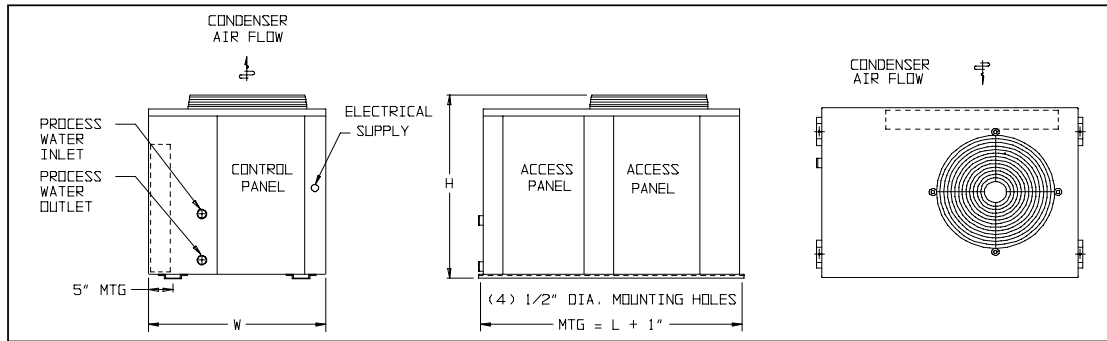

Legacy Model	BTUH @ 95°F amb. 45°F Lwt	Length Inches	Width Inches	Height Inches	Fluid Conn.	Compressor		RLA ea.	LRA ea.	Fan Motor		MCA	M.O.P.	Weight Pounds
						Qty.	HP			Qty.	FLA			
180S2-T3-Z	148,800	157	45	54.5	2" MPT	1	15	55.2	425.0	2	6.6	90	125	1600
180S2-T4-Z														
250S2-T3-Z	210,000	157	45	54.5	2.5" MPT	1	20	81.0	505.0	2	6.6	125	175	1700
250S2-T4-Z														
300S2-T3-Z	248,400	157	45	54.5	2.5" MPT	1	25	87.9	500.0	2	6.6	125	200	1800
300S2-T4-Z														

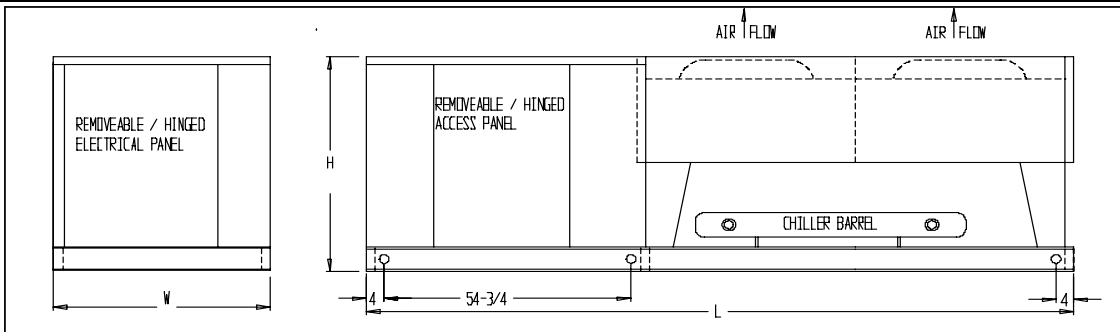

PAC DIMENSIONAL & ELECTRICAL SPECIFICATIONS

Dual circuit packaged air cooled chiller

Legacy Model	BTUH @ 95°F amb. 45°F Lwt	Length Inches	Width Inches	Height Inches	Fluid Conn.	Compressor		RLA ea.	LRA ea.	Fan Motor		MCA	M.O.P.	Weight Pounds
						Qty.	HP			Qty.	FLA ea.			
72D2-S2-Z	84,000	75	34	47	1.25" FPT	2	4	25.0	132	2	3.3	70	80	900
72D2-T3-Z								15.0	115		3.3	45	50	
72D2-T4-Z								7.4	47.5		1.6	20	25	
96D2-S2-Z	104,400	85	40	47	1.25" FPT	2	5	30.1	175	2	3.3	80	100	1000
96D2-T3-Z								20.7	115		3.3	60	70	
96D2-T4-Z								8.9	63		1.6	25	30	
100D2-S2-Z	115,200	85	40	47	1.25" FPT	2	5	27.9	129	2	3.3	70	90	1100
120D2-T3-Z	20.7							156	3.3		60	70		
120D2-T4-Z	11.5							70	1.6		30	40		
140D2-T3-Z	164,400	85	40	47	1.25" FPT	2	8	32.1	195	2	3.3	80	110	1400
140D2-T4-Z								16.4	95		1.6	45	50	
160D2-T3-Z								33.6	225		3.3	90	110	
160D2-T4-Z	186,000	85	40	47	1.5" FPT	2	9	17.3	114	2	1.6	45	50	1450
180D2-T3-Z	42.0							239	3.3		110	125		
180D2-T4-Z	19.2							125	1.6		45	60		

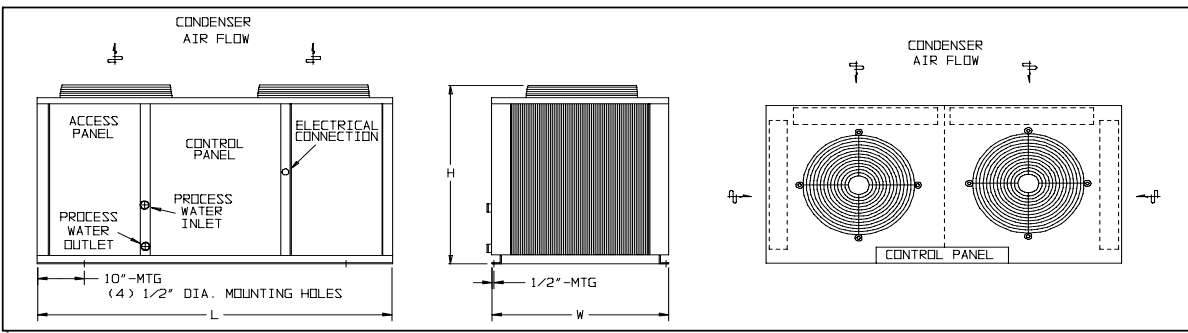

Legacy Model	BTUH @ 95°F amb. 45°F Lwt	Length Inches	Width Inches	Height Inches	Fluid Conn.	Compressor		RLA ea.	LRA ea.	Fan Motor		MCA	M.O.P.	Weight Pounds
						Qty.	HP			Qty.	FLA ea.			
240D2-T3-Z	246,000	66	75	49	1.5" FPT	2	12	47.0	245	4	3.3	125	150	1750
240D2-T4-Z								22.1	125		1.6	60	70	

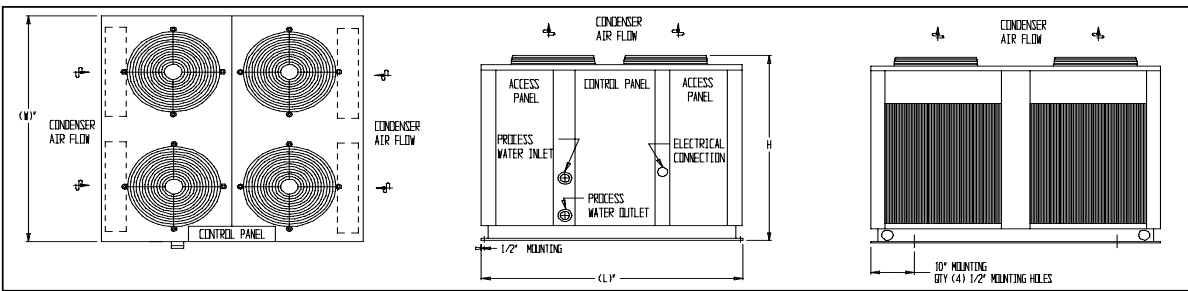

Legacy Model	BTUH @ 95°F amb. 45°F Lwt	Length Inches	Width Inches	Height Inches	Fluid Conn.	Compressor		RLA ea.	LRA ea.	Fan Motor		MCA	M.O.P.	Weight Pounds
						Qty.	HP			Qty.	FLA ea.			
360D2-T3-Z	303,600	204	45	54.5	2.5" MPT	2	15	55.2	425	3	6.6	150	175	2600
360D2-T4-Z								27.2	187		3.1	80	90	
500D2-T3-Z	420,000	157	88	54.5	3" MPT	2	20	81.0	505	4	6.6	225	250	2900
500D2-T4-Z								34.0	225		3.1	90	110	
600D2-T3-Z	507,600	183	88	54.5	3" MPT	2	25	87.9	500	4	6.6	225	300	3200
600D2-T4-Z								43.0	250		3.1	110	150	

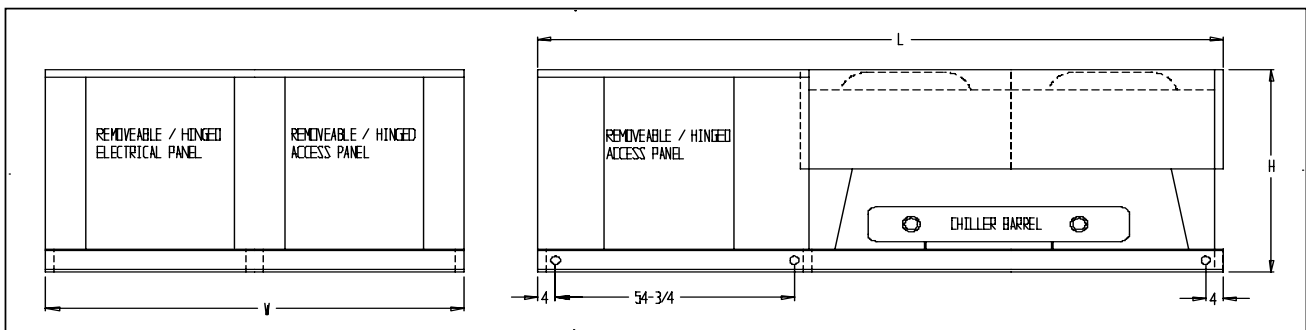

Standard Available Stainless Steel Process System Pumps

1MS & 2MS PUMPS

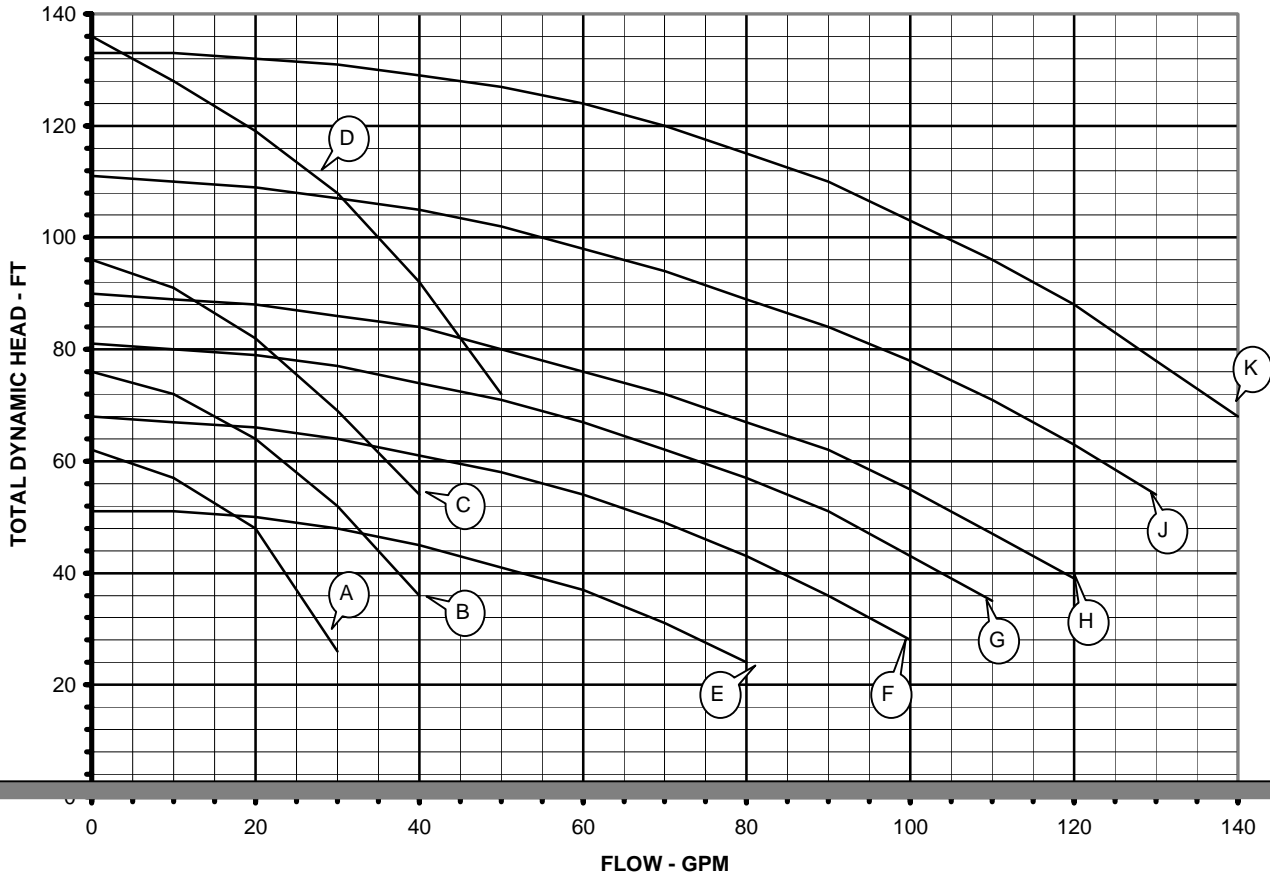

- | | | | | |
|--------------|----------------|--------------|----------------|------------|
| A) 1/3HP 1MS | C) 3/4HP 1MS | E) 3/4HP 2MS | G) 1-1/2HP 2MS | J) 3HP 2MS |
| B) 1/2HP 1MS | D) 1-1/2HP 1MS | F) 1HP 2MS | H) 2HP 2MS | K) 5HP 2MS |

** Legacy chillers are not limited to the pumps shown on this curve. Contact the factory @ (877) 988-5464 with the flow and head pressure requirements to have the proper pump selected for your application.

Certain applications may require the use of glycol (antifreeze) depending on cooling requirements and / or low ambient temperatures. These fluids affect chiller capacities and may require heat exchanger adjustments. Please consult the factory for assistance.

**TANK SECTION
DIMENSIONAL
SPECIFICATIONS**



TS 135s tank section

Legacy Model	Length Inches	Width Inches	Height Inches	Water Connection	Tank Capacity	Recirc. Pump	RLA 230/3Ø	RLA 460/3Ø	Weight Pounds
TS30S	36	36	36	1" FPT	30 Gal.	1/3HP	1.4	1.4	500
TS60S	56	36	36	1" FPT	60 Gal.	1/3HP	1.4	1.4	525
TS90S	75	36	36	1 1/4" FPT	90 Gal.	1/2HP	1.8	1.8	540
TS135S	85	36	36	1 1/2" FPT	135 Gal.	3/4HP	2.6	1.3	560

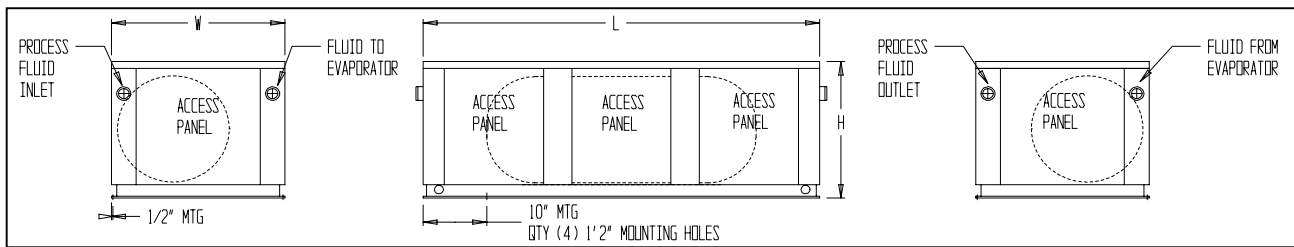

STANDARD FEATURES

- **STAINLESS STEEL** storage tank
- 1/2" tank and fluid piping insulation
- Copper fluid piping
- Tank vent and drain connections
- Tank pressure relief valve
- Fused evaporator fluid re-circulating **STAINLESS STEEL** pump
- Fluid pump discharge ball valve and cleanable "Y" strainer
- Control box with pump terminal block
- Painted galvanized steel sheet metal cabinet
- 24 volt L.E.D. process fluid thermometers

AVAILABLE OPTIONS

- Fused **STAINLESS STEEL** process pump
- Tank fluid sight glass
- Tank liquid level indicator with dry contacts
- **STAINLESS STEEL** piping for reverse osmosis or de-ionized water applications
- **STAINLESS STEEL** sheet metal cabinet
- 1" tank and piping insulation in lieu of 1/2"
- Seal-tight electrical connections

Legacy Chiller Systems, Inc.

Fluid cooling and conditioning solutions for fermentation process

877-988-5464

TANK SECTION DIMENSIONAL SPECIFICATIONS



TS 600s tank section

Legacy Model	Length Inches	Width Inches	Height Inches	Water Connection	Tank Capacity	Recirc. Pump	RLA 230/3Ø	RLA 460/3Ø	Weight Pounds
TS200S	120	56	59	1 1/2" FPT	200 Gal.	2HP	1.4	0.7	500
TS300S	120	56	59	2" FPT	300 Gal.	2HP	1.4	0.7	525
TS500S	120	56	59	3"	500 Gal.	3HP	2.6	1.3	540
TS600S	120	56	59	4"	600 Gal.	3HP	2.6	1.3	560

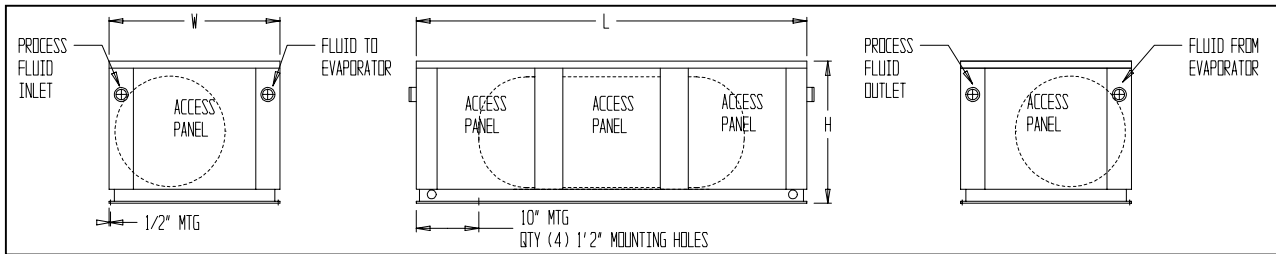

STANDARD FEATURES

- Open vented **polyethylene** storage tank
- 1/2" tank and fluid piping insulation
- Copper fluid piping
- Tank vent and drain connections
- Fused **STAINLESS STEEL** evaporator fluid re-circulating pump
- Fluid pump discharge ball valve and cleanable "Y" strainer
- Control box with pump terminal block
- Painted galvanized sheet metal cabinet
- 24 volt L.E.D. process fluid thermometers

AVAILABLE OPTIONS

- Fluid flow meter
- Fused **STAINLESS STEEL** process pump
- Tank fluid sight glass
- Tank liquid level indicator with dry contacts
- **STAINLESS STEEL** piping for reverse osmosis or de-ionized water applications
- **STAINLESS STEEL** sheet metal cabinet
- 1" tank and piping insulation in lieu of 1/2"
- Seal-tight electrical connections
- Suction diffuser
- Three way valve (system pump discharge)
- **STAINLESS STEEL** (welded) tank

Legacy Chiller Systems, Inc.

Fluid cooling and conditioning solutions for Mission Critical process applications

877-988-5464



AIR COOLED SCROLL CHILLER CAPACITY TABLE

Legacy Model	Compressor	LWT °F	80			90			95			100			105		
			TONS	KW	EER	TONS	KW	EER	TONS	KW	EER	TONS	KW	EER	TONS	KW	EER
12S	ZR16KC	42.0	1.2	1.2	7.5	1.2	1.3	6.8	1.1	1.4	6.3	1.1	1.4	6.0	1.1	1.5	5.6
		44.0	1.3	1.2	7.7	1.2	1.3	6.9	1.2	1.4	6.5	1.1	1.4	6.2	1.1	1.5	5.8
		45.0	1.3	1.2	7.8	1.2	1.3	7.0	1.2	1.4	6.6	1.2	1.4	6.3	1.1	1.5	5.9
		50.0	1.4	1.2	8.4	1.3	1.3	7.5	1.3	1.4	7.1	1.3	1.5	6.7	1.2	1.6	6.3
18S	ZR15KC	42.0	1.8	1.7	8.9	1.7	1.8	7.9	1.7	1.9	7.4	1.6	2.0	7.0	1.6	2.2	6.5
		44.0	1.9	1.7	9.1	1.8	1.9	8.1	1.7	2.0	7.6	1.7	2.1	7.2	1.6	2.2	6.7
		45.0	1.9	1.7	9.3	1.8	1.9	8.3	1.8	2.0	7.7	1.7	2.1	7.3	1.7	2.2	6.8
		50.0	2.1	1.8	9.9	2.0	1.9	8.8	1.9	2.0	8.3	1.9	2.1	7.8	1.8	2.2	7.3
24S	ZR19KC	42.0	2.2	1.9	9.7	2.1	2.1	8.6	2.0	2.2	8.1	2.0	2.3	7.6	2.0	2.4	7.1
		44.0	2.2	1.9	10.0	2.1	2.1	8.9	2.1	2.2	8.4	2.0	2.3	7.9	2.0	2.4	7.4
		45.0	2.3	1.9	10.2	2.2	2.1	9.1	2.1	2.2	8.5	2.1	2.3	8.0	2.1	2.5	7.5
		50.0	2.5	1.9	10.9	2.4	2.1	9.7	2.3	2.3	9.2	2.3	2.4	8.6	2.2	2.5	8.1
30S	ZB26KC	42.0	3.1	2.8	10.4	2.9	3.1	9.1	2.9	3.3	8.4	2.8	3.5	7.9	2.7	3.7	7.3
		44.0	3.2	2.8	10.6	3.1	3.2	9.3	3.0	3.4	8.7	2.9	3.5	8.2	2.9	3.7	7.6
		45.0	3.3	2.9	10.8	3.1	3.2	9.5	3.0	3.4	8.8	3.0	3.5	8.3	2.9	3.7	7.7
		50.0	3.5	2.9	11.4	3.4	3.3	10.0	3.3	3.5	9.3	3.2	3.6	8.8	3.1	3.8	8.2
36S	ZB30KC	42.0	3.6	3.4	10.3	3.5	3.8	9.2	3.3	3.9	8.6	3.3	4.1	8.1	3.2	4.3	7.6
		44.0	3.8	3.5	10.6	3.6	3.8	9.4	3.4	4.0	8.8	3.4	4.1	8.4	3.3	4.4	7.8
		45.0	3.8	3.5	10.8	3.7	3.8	9.6	3.5	4.0	9.0	3.5	4.2	8.5	3.4	4.4	7.9
		50.0	4.2	3.6	11.4	4.0	3.9	10.2	3.8	4.1	9.6	3.8	4.3	9.1	3.7	4.5	8.5
48S	ZB38KC	42.0	4.3	4.0	10.9	4.1	4.4	9.5	4.0	4.6	8.9	3.9	4.8	8.3	3.8	5.1	7.7
		44.0	4.5	4.0	11.2	4.3	4.4	9.8	4.2	4.6	9.2	4.0	4.9	8.6	3.9	5.1	8.0
		45.0	4.6	4.0	11.3	4.3	4.4	9.9	4.2	4.7	9.3	4.1	4.9	8.7	4.0	5.2	8.1
		50.0	5.0	4.2	12.1	4.8	4.6	10.6	4.6	4.8	10.0	4.5	5.0	9.4	4.4	5.3	8.7
50S	ZB42KC	42.0	4.8	4.3	11.2	4.6	4.8	9.7	4.4	5.1	9.0	4.3	5.4	8.4	4.2	5.8	7.7
		44.0	5.0	4.4	11.5	4.7	4.9	10.0	4.6	5.2	9.2	4.5	5.5	8.6	4.4	5.9	7.9
		45.0	5.1	4.4	11.6	4.8	4.9	10.1	4.7	5.2	9.3	4.6	5.5	8.7	4.5	5.9	8.0
		50.0	5.5	4.6	12.3	5.3	5.1	10.7	5.1	5.4	9.8	5.0	5.7	9.2	4.8	6.1	8.5
60S	ZB45KC	42.0	5.4	4.6	12.0	5.1	5.1	10.5	5.0	5.4	9.7	4.9	5.7	9.1	4.7	6.0	8.4
		44.0	5.6	4.6	12.3	5.3	5.2	10.7	5.2	5.4	10.0	5.0	5.7	9.3	4.9	6.1	8.6
		45.0	5.7	4.7	12.5	5.4	5.2	10.9	5.3	5.5	10.1	5.2	5.8	9.4	5.0	6.1	8.7
		50.0	6.2	4.8	13.2	5.9	5.3	11.6	5.7	5.6	10.7	5.6	5.9	10.0	5.4	6.2	9.3

1. Capacities on this chart are based on refrigerant 22. Low ambient or lower leaving water temperatures can require the use of a glycol solution or other fluid blends. These solutions affect unit capacities. Please consult the factory on these or other special fluids.

2. kW input is for compressor(s) only.

3. EER = Energy Efficiency Ratio (BTU/watt-hour). Power inputs include compressor(s), condenser fan motor(s) and control power



AIR COOLED SCROLL CHILLER CAPACITY TABLE

Legacy Model	Compressor	LWT °F	80			90			95			100			105		
			TONS	KW	EER	TONS	KW	EER	TONS	KW	EER	TONS	KW	EER	TONS	KW	EER
70S	ZB58KC	42.0	7.0	5.9	11.1	6.6	6.6	9.8	6.4	6.9	9.1	6.3	7.3	8.5	6.1	7.7	8.0
		44.0	7.2	6.0	11.4	6.8	6.6	10.0	6.7	7.0	9.4	6.5	7.3	8.8	6.3	7.7	8.2
		45.0	7.3	6.0	11.6	6.9	6.7	10.2	6.8	7.0	9.6	6.6	7.4	9.0	6.5	7.8	8.4
		50.0	7.9	6.2	12.3	7.6	6.8	10.8	7.3	7.2	10.2	7.2	7.5	9.6	7.1	7.9	9.0
80S	ZB66KC	42.0	7.9	7.1	10.9	7.5	7.8	9.7	7.3	8.2	9.1	7.2	8.6	8.5	7.0	9.0	8.0
		44.0	8.1	7.2	11.2	7.8	7.9	9.9	7.6	8.3	9.3	7.4	8.6	8.8	7.3	9.1	8.2
		45.0	8.3	7.2	11.4	7.9	7.9	10.1	7.8	8.3	9.5	7.6	8.7	8.9	7.4	9.1	8.4
		50.0	8.9	7.4	12.0	8.6	8.1	10.7	8.4	8.5	10.1	8.3	8.8	9.6	8.1	9.3	8.9
90S	ZB76KC	42.0	9.0	8.4	10.8	8.6	9.2	9.6	8.4	9.7	9.0	9.0	10.1	8.4	8.0	10.6	7.9
		44.0	9.3	8.5	11.1	8.9	9.3	9.8	8.7	9.7	9.2	8.5	10.2	8.7	8.3	10.7	7.2
		45.0	9.5	8.6	11.3	9.1	9.3	10.0	8.9	9.8	9.4	8.7	10.3	8.9	8.5	10.7	7.3
		50.0	10.3	8.7	12.0	9.8	9.5	10.7	9.6	10.0	10.0	9.4	10.5	9.4	9.2	10.9	7.9
120S	ZB88KC	42.0	10.5	9.1	11.9	10.0	10.0	10.4	9.7	10.5	9.7	9.5	11.1	9.1	9.2	11.7	8.4
		44.0	10.8	9.2	12.2	10.3	10.1	10.7	10.1	10.6	9.9	9.8	11.2	9.3	9.5	11.8	8.6
		45.0	11.0	9.2	12.4	10.5	10.2	10.8	10.3	10.7	10.0	10.0	11.2	9.4	9.7	11.9	8.7
		50.0	11.9	9.5	13.0	11.3	10.4	11.4	11.1	11.0	10.7	10.8	11.5	10.0	10.5	12.1	9.3
180S	ZB11M	42.0	13.1	11.8	10.3	12.5	13.1	9.0	11.8	13.8	8.4	11.8	14.6	7.9	11.6	15.4	7.3
		44.0	13.5	11.9	10.5	12.8	13.2	9.2	12.2	13.9	8.6	12.2	14.7	8.1	11.9	15.4	7.6
		45.0	13.7	11.9	10.6	13.0	13.2	9.3	12.4	14.0	8.7	12.4	14.7	8.2	12.1	15.5	7.7
		50.0	14.7	12.1	11.3	14.0	13.4	10.9	13.3	14.2	9.3	13.3	14.9	8.7	13.0	15.7	8.1
250S	ZR250K	42.0	17.7	16.3	10.7	17.0	18.0	9.4	16.6	18.9	8.9	16.3	19.8	8.4	15.8	20.8	7.8
		44.0	18.3	16.6	10.9	17.5	18.2	9.6	17.1	19.1	9.1	16.8	20.0	8.6	16.4	21.1	8.0
		45.0	18.6	16.6	11.0	17.8	18.3	9.8	17.5	19.2	9.2	17.1	20.1	8.7	16.7	21.2	8.1
		50.0	20.0	17.1	11.6	19.3	18.8	10.4	18.9	19.7	9.7	18.5	20.6	9.2	17.9	21.7	8.6
300S	ZR300K	42.0	21.0	19.4	11.0	20.2	21.3	9.8	19.8	22.8	9.2	19.4	23.4	8.6	18.8	24.6	8.0
		44.0	21.8	19.6	11.3	20.8	21.6	10.0	20.4	22.6	9.4	20.0	23.6	8.8	19.5	24.8	8.2
		45.0	22.1	19.7	11.4	21.2	21.7	10.1	20.7	22.7	9.5	20.3	23.7	8.9	19.8	25.0	8.5
		50.0	23.9	20.8	12.0	22.9	22.2	10.7	22.3	23.4	10.0	21.9	24.3	9.5	21.4	25.6	8.8

1. Capacities on this chart are based on refrigerant 22. Low ambient or lower leaving water temperatures can require the use of a glycol solution or other fluid blends. These solutions affect unit capacities. Please consult the factory on these or other special fluids.

2. kW input is for compressor(s) only.

3. EER = Energy Efficiency Ratio (BTU/watt-hour). Power inputs include compressor(s), condenser fan motor(s) and control power



AIR COOLED SCROLL CHILLER CAPACITY TABLE

Legacy Model	Compressor	LWT °F	80			90			95			100			105		
			TONS	KW	EER	TONS	KW	EER	TONS	KW	EER	TONS	KW	EER	TONS	KW	EER
72D	ZB30KC	42.0	7.1	7.1	9.8	6.8	7.8	8.7	6.6	8.2	8.2	6.5	8.5	7.7	6.3	8.9	7.2
		44.0	7.4	7.2	10.1	7.0	7.9	9.0	6.9	8.3	8.5	6.7	8.6	7.9	6.5	9.0	7.5
		45.0	7.5	7.3	10.3	7.2	7.9	9.1	7.0	8.3	8.6	6.8	8.7	8.0	6.7	9.1	7.6
		50.0	8.1	7.4	10.9	7.8	8.1	9.7	7.6	8.4	9.1	7.4	8.8	8.6	7.2	9.2	8.1
96D	ZB38KC	42.0	8.8	7.8	11.4	8.3	8.5	10.0	8.1	8.9	9.3	7.9	9.4	8.6	7.7	9.9	8.1
		44.0	9.2	7.8	11.7	8.7	8.6	10.3	8.5	9.0	9.6	8.2	9.5	9.0	8.0	10.0	8.4
		45.0	9.3	7.9	11.9	8.9	8.7	10.4	8.7	9.1	9.8	8.4	9.6	9.1	8.2	10.0	8.5
		50.0	10.2	8.1	12.6	9.7	8.9	11.2	9.4	9.3	10.4	9.2	9.8	9.8	9.0	10.3	9.2
100D	ZB42KC	42.0	9.8	8.4	11.8	9.3	9.4	10.2	9.1	9.9	9.5	8.8	10.5	8.8	8.6	11.2	8.1
		44.0	10.2	8.5	12.1	9.7	9.5	10.5	9.4	10.1	9.7	9.2	10.6	9.0	8.9	11.3	8.3
		45.0	10.3	8.6	12.3	9.8	9.6	10.6	9.6	10.1	9.9	9.3	10.7	9.2	9.1	11.4	8.4
		50.0	11.2	8.9	13.0	10.7	9.8	11.3	10.5	10.4	10.5	10.2	11.0	9.8	9.9	11.7	9.0
120D	ZB45KC	42.0	10.6	9.2	12.0	10.2	10.2	10.5	10.0	10.7	9.7	9.7	11.3	9.1	9.5	11.9	8.4
		44.0	11.1	9.3	12.3	10.6	10.3	10.7	10.3	10.8	10.0	10.1	11.4	9.4	9.8	12.0	8.7
		45.0	11.4	9.4	12.5	10.8	10.4	10.9	10.6	10.9	10.2	10.3	11.5	9.5	10.1	12.1	8.8
		50.0	12.3	9.7	13.2	11.8	10.7	11.6	11.4	11.2	10.8	11.2	11.7	10.1	10.9	12.4	9.4
140D	ZB58KC	42.0	13.9	11.8	12.5	13.2	13.1	10.8	12.9	13.8	10.1	12.6	14.5	9.4	12.3	15.3	8.7
		44.0	14.4	11.9	12.8	13.7	13.2	11.2	13.4	13.9	10.4	13.1	14.6	9.7	12.8	15.4	9.0
		45.0	14.6	12.0	13.0	14.0	13.3	11.3	13.7	14.0	10.6	13.3	14.7	9.8	13.0	15.5	9.2
		50.0	15.7	12.3	13.7	15.2	13.6	12.0	14.7	14.3	11.2	14.4	15.0	10.5	14.0	15.8	9.8
160D	ZB66KC	42.0	15.3	14.0	11.8	14.6	15.5	10.3	14.3	16.2	9.7	13.9	17.1	9.0	13.5	17.9	8.4
		44.0	16.3	14.3	12.3	15.5	15.7	10.8	15.2	16.5	10.1	14.8	17.3	9.4	14.5	18.2	8.8
		45.0	16.5	14.4	12.5	15.8	15.8	10.9	15.5	16.6	10.3	15.2	17.4	9.6	14.8	18.3	8.9
		50.0	17.8	14.8	13.2	17.1	16.2	11.6	16.8	17.0	10.8	16.4	17.8	10.2	16.0	18.7	9.5
180D	ZB76KC	42.0	17.9	16.8	11.7	17.2	18.5	10.3	16.9	19.4	9.7	16.4	20.3	9.0	16.0	21.4	8.4
		44.0	18.5	17.0	12.0	17.7	18.7	10.5	17.3	19.6	9.8	17.0	20.6	9.2	16.5	21.6	8.6
		45.0	18.9	17.1	12.1	18.1	18.8	10.7	17.7	19.7	10.0	17.3	20.7	9.4	16.9	21.7	8.7
		50.0	20.3	17.6	12.8	19.5	19.3	11.3	19.0	20.3	10.4	18.7	21.2	9.9	18.2	22.2	9.2
180M	ZB38KC	42.0	13.1	11.2	12.2	12.5	12.5	10.5	12.2	13.2	9.7	11.9	14.0	9.0	11.5	14.8	8.3
		44.0	13.6	11.2	12.6	12.9	12.5	10.9	12.7	13.2	10.1	12.3	14.0	9.4	12.0	14.9	8.6
		45.0	13.9	11.2	12.8	13.1	12.5	11.1	12.8	13.2	10.3	12.5	14.0	9.5	12.1	14.9	8.8
		50.0	14.8	11.3	13.7	14.3	12.6	11.9	13.8	13.3	11.1	13.5	14.1	10.2	13.1	14.9	9.5

1. Capacities on this chart are based on refrigerant 22. Low ambient or lower leaving water temperatures can require the use of a glycol solution or other fluid blends. These solutions affect unit capacities. Please consult the factory on these or other special fluids.

2. kW input is for compressor(s) only.

3. EER = Energy Efficiency Ratio (BTU/watt-hour). Power inputs include compressor(s), condenser fan motor(s) and control power



AIR COOLED SCROLL CHILLER CAPACITY TABLE

Legacy Model	Compressor	LWT °F	80			90			95			100			105		
			TONS	KW	EER	TONS	KW	EER	TONS	KW	EER	TONS	KW	EER	TONS	KW	EER
240D	ZB88KC	42.0	20.9	18.0	12.0	20.0	19.8	10.5	19.4	20.8	9.8	18.9	21.8	9.2	18.5	23.0	8.5
		44.0	21.7	18.2	12.3	20.7	20.0	10.7	20.1	21.0	10.0	19.7	22.0	9.4	19.2	23.2	8.8
		45.0	22.1	18.2	12.5	21.0	20.1	10.9	20.5	21.1	10.2	20.0	22.2	9.6	19.6	23.3	8.9
		50.0	23.8	18.8	13.1	22.8	20.6	11.6	22.1	21.6	10.8	21.7	22.6	10.2	21.3	23.7	9.5
360D	ZB11M	42.0	26.0	23.4	10.9	24.8	26.0	9.5	24.2	27.5	8.9	23.7	28.9	8.3	23.0	30.5	7.7
		44.0	26.7	23.5	11.2	25.2	26.2	9.7	24.9	27.6	9.1	24.3	29.1	8.5	23.7	30.7	7.9
		45.0	27.2	23.6	11.3	25.9	26.3	9.9	25.3	27.7	9.2	24.8	29.2	8.6	24.1	30.8	8.0
		50.0	29.1	23.9	12.0	27.8	26.6	10.5	27.1	28.1	9.7	26.5	29.5	9.1	25.8	31.1	8.5
500D	ZR250K	42.0	35.4	33.0	10.7	33.9	36.1	9.5	33.3	37.8	8.9	32.5	39.5	8.4	31.7	41.6	7.8
		44.0	36.7	33.3	11.0	35.1	36.5	9.7	34.4	38.3	9.1	33.7	39.9	8.6	32.9	42.0	8.0
		45.0	37.3	33.5	11.1	35.8	36.8	9.8	35.0	38.5	9.2	34.3	40.1	8.7	33.3	42.2	8.1
		50.0	40.3	34.5	11.7	38.7	37.8	10.4	37.8	39.5	9.8	37.2	41.0	9.3	36.3	43.2	8.6
600D	ZR300K	42.0	42.8	37.7	11.5	41.1	41.4	10.2	40.2	43.4	9.6	39.3	45.4	9.0	38.4	47.7	8.4
		44.0	44.2	38.1	11.8	42.5	41.8	10.5	41.6	43.7	9.8	40.8	45.8	9.3	39.8	48.1	8.7
		45.0	45.0	38.3	11.9	43.3	42.0	10.6	42.3	74.0	10.0	41.4	46.0	9.4	40.4	18.3	8.8
		50.0	48.8	39.4	12.6	46.8	43.0	11.2	45.8	44.9	10.6	44.9	46.8	10.0	43.8	49.2	9.4

1. Capacities on this chart are based on refrigerant 22. Low ambient or lower leaving water temperatures can require the use of a glycol solution or other fluid blends. These solutions affect unit capacities. Please consult the factory on these or other special fluids.

2. kW input is for compressor(s) only.

3. EER = Energy Efficiency Ratio (BTU/watt-hour). Power inputs include compressor(s), condenser fan motor(s) and control power